

SECTION A-A

1 : 1

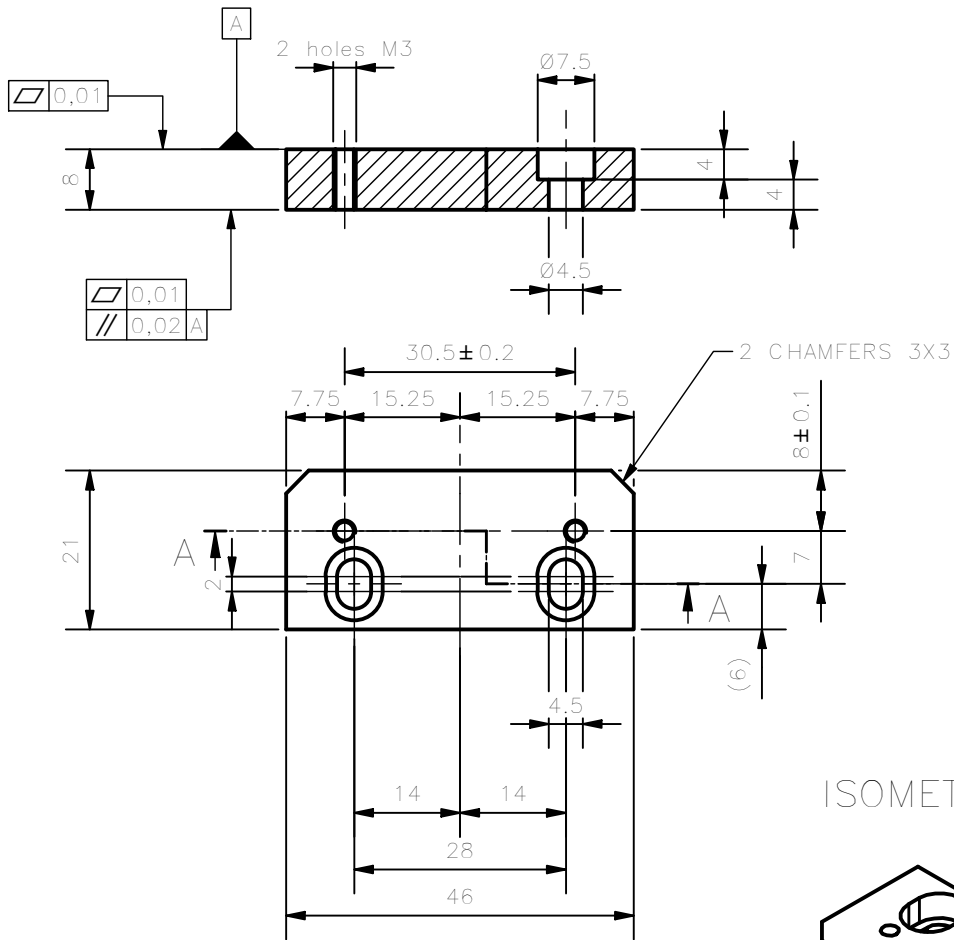

ISOMETRIC VIEW

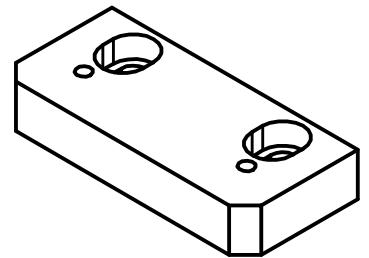

NOTE:

UNCOATED SURFACES MACHINED MUST BE PROTECTED WITH OIL.



**EIE GROUP**

via Torino 151A - Mestre  
Venezia - 30172 - ITALY  
tel. +39 041 5317906 - www.eie.it

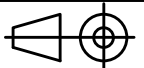

**ASTRI mini-array - CTA Small Size Telescope prototypes**

Material: Construction steel S355J0 EN10027		Surface:		Tolerances according to: ISO 2768/1-m ISO 2768/2-k		Roughness:		Commissa/Job no.: <b>G0113</b>		 <small>VIEWS AND SECTIONS ARE TO BE WORKED WITH REFERENCE TO EUROPEAN DWG SYSTEM</small>																	
Status:		Mass: 0,05 kg		Scale: 1:1		Naming: Mount Assembly Base structure Base AZ encoder head plate upper		Drawing N.		Sheet: 1 / 1																	
<table border="1"> <tr> <td>Designed</td> <td>13/01/2014</td> <td colspan="2">Name:</td> <td colspan="2">SG</td> </tr> <tr> <td>Checked</td> <td>20/02/2014</td> <td colspan="2">Name:</td> <td colspan="2">AB</td> </tr> <tr> <td>Approved</td> <td>20/02/2014</td> <td colspan="2">Name:</td> <td colspan="2">GPM</td> </tr> </table>		Designed	13/01/2014	Name:		SG		Checked	20/02/2014	Name:		AB		Approved	20/02/2014	Name:		GPM		Date:		Name:		Drawing N.		Sheet:	
Designed	13/01/2014	Name:		SG																							
Checked	20/02/2014	Name:		AB																							
Approved	20/02/2014	Name:		GPM																							
<table border="1"> <tr> <td>A</td> <td>First Issue</td> <td>AC</td> <td>04.03.21</td> </tr> <tr> <td>Rev</td> <td>Modification</td> <td>Name</td> <td>Date</td> </tr> </table>		A	First Issue	AC	04.03.21	Rev	Modification	Name	Date	Date:		Name:		Drawing N.		Sheet:											
A	First Issue	AC	04.03.21																								
Rev	Modification	Name	Date																								
<table border="1"> <tr> <td colspan="2">Drawing size:</td> <td colspan="2">A4</td> </tr> </table>		Drawing size:		A4		Date:		Name:		Drawing N.		Sheet:															
Drawing size:		A4																									
<table border="1"> <tr> <td colspan="2">Drawing size:</td> <td colspan="2">A4</td> </tr> </table>		Drawing size:		A4		Date:		Name:		Drawing N.		Sheet:															
Drawing size:		A4																									

ALL RIGHTS BELONG TO EIE GROUP Srl  
NO COPIES, REPRODUCTION OR DISSEMINATION ARE PERMITTED.

Filename: AZ encoder head plate upper.iprt